

LINEAR AMPLIFIER

Model A400DI



TWO-CHANNELS 20x AMPLIFIER WITH PHASE INVERTER

HIGH VOLTAGE

800 V_{pp} differential

BROADBAND

DC to 1 MHz

HIGH SLEW RATE

≥ 300 V/μs

LOW OUTPUT IMPEDANCE

< 0.1 Ω

Address:

FLC Electronics AB
Sippedalsvägen 8
S - 433 31 Partille
Sweden

Fax:

+46 (0)31 340 1848
+46 (0)31 741 2630

Electronic mail:

flce@flce.se

VAT No:

SE556506606401

Web:

http://www.flce.se

GENERAL DESCRIPTION

The **A400DI** is a general purpose linear amplifier designed for laboratory use. It is based on a fast high-voltage operational amplifier with a feedback network chosen to give a voltage amplification of 20 times. Any function or arbitrary waveform generator with low output impedance and output voltage up to ± 10 V can be used as an input device. The instrument contains **two identical amplifiers**, which share the power supply.

PHASE INVERTER

The **A400DI** contains a phase inverter which shares the input with amplifier “1”. It is intended to allow differential connection of the amplifiers to achieve double amplitude of the output signal. In such a case, the output of the phase inverter should be connected to the input of the second amplifier, an external signal supplied to the input of the first amplifier and the load connected between the outputs of both amplifiers as in the example below:

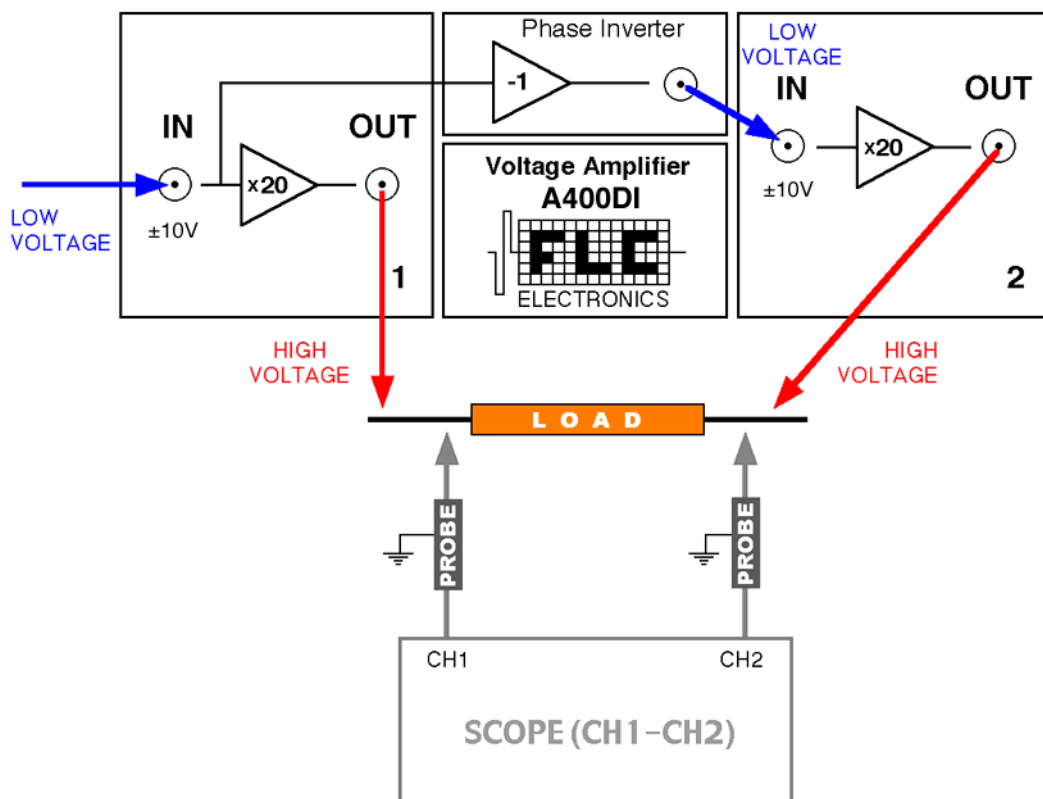

Observe, that both sides of the connected load are active and must be isolated from ground. The voltage over the load is in this case $U_1 - U_2 = U_1 - (-U_1) = 2U_1$ since $U_2 = -U_1$.

It is, of course, possible to supply separate signals to the low voltage inputs of both amplifiers and still use the differential connection of the load, as in the drawing.

The amplifiers can also be used as two independent units sharing the common ground reference.

Never connect any high voltage output to any input or output of the instrument!

In the differential configuration - isolate the load from ground and use two separate oscilloscope probes to monitor the voltage over the load.

INPUT AMPLITUDE

The input amplitude should normally be kept within ± 10 V and not exceed ± 12 V. This is most important since the input protection network will limit the signal amplitude and cause distortion. The input protection network effectively cuts accidental spikes and overshoots. It is equipped with a fuse rated at 15 mA, which will be blown if the input voltage exceeds 300% of the maximum.

Keep input signals within ± 10 V range. Never connect the output to the input of the amplifier!

LOAD

The amplifier is intended to drive resistive and/or small capacitive loads. The maximum capacitive load depends on the slew rate of the amplifier. This is normally set at the factory to 300 V/ μ s which yields the load limit of 450 pF. This limit includes the capacitance of the connection cable (ca 100 pF/m for a standard coaxial cable). Increasing the capacitive load causes overshoot to appear. If a larger capacitive load is required then the slew rate should be reduced accordingly. Such an adjustment may be performed by qualified personnel and the factory should be contacted for advice. Inside the cabinet exist hazardous voltage levels and the amplifier circuit is extremely sensitive to static discharge.

Overloading the output may cause an overshoot which might be dangerous for connected devices.

In the extreme case the overshoot can reach -200 V. FLC Electronics Inc. recommends to monitor the output signal of the amplifier with an oscilloscope. It is then important to use a low capacitive probe with a division factor of at least 1/10.

The amplifier cannot be used to drive a purely inductive load. Small (mH) inductances in series with resistance can be used.

The continuous output current limit is 100 mA and the output power limit is 10 W (total power dissipation is then 16 W), which corresponds to Safe Operating Area (SOA). The temporary peak current may be up to 170 mA. The output is equipped with a current limiting circuit which withstands accidental short-circuits. It, however, does not constitute sufficient protection against prolonged short-circuiting or overload. The following three figures present the measurements of the worst case power dissipation as a function of frequency, load and input amplitude, respectively.

The amplifier may be overheated when the output is short-circuited for a very long time.

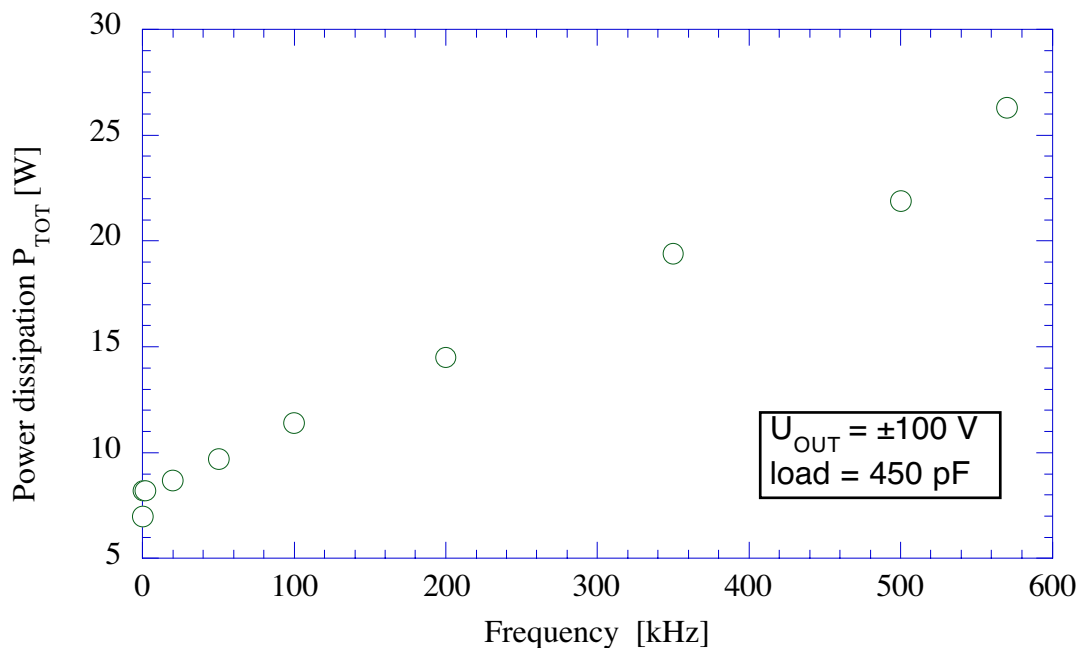

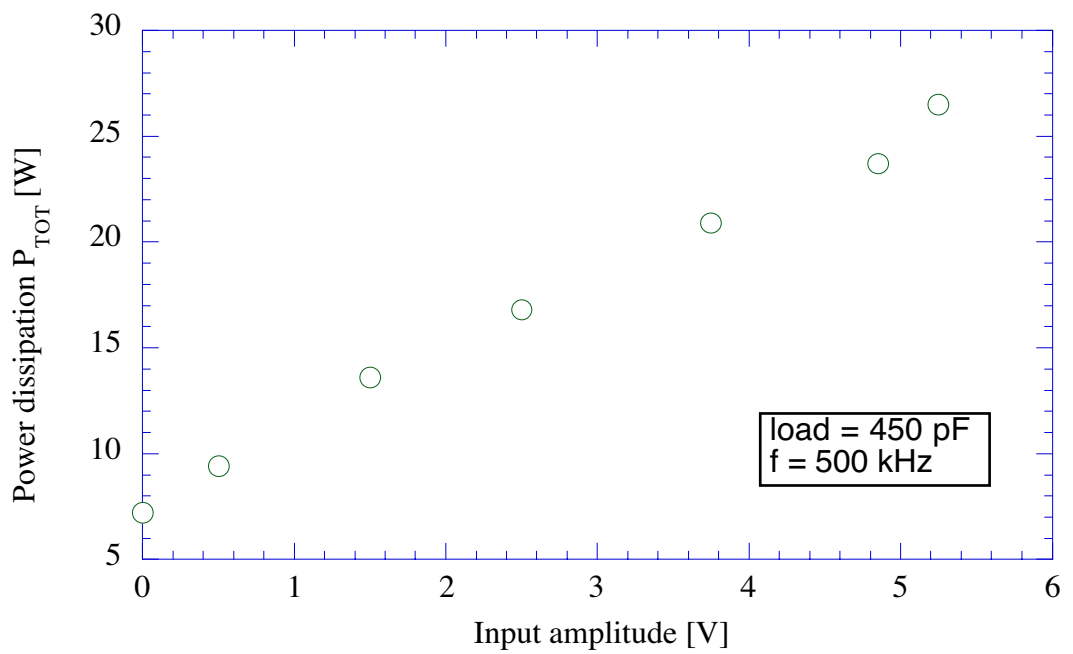
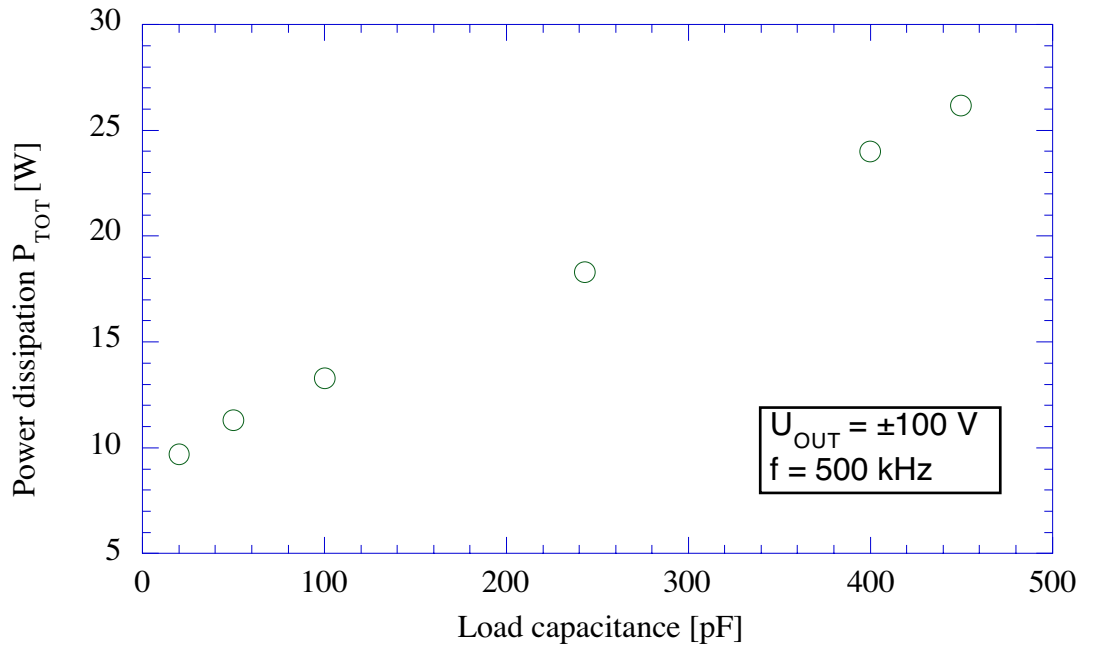

FREQUENCY RESPONSE

The frequency response to 50% and 100% of the input amplitude and with 450 pF load is shown in the following diagram:

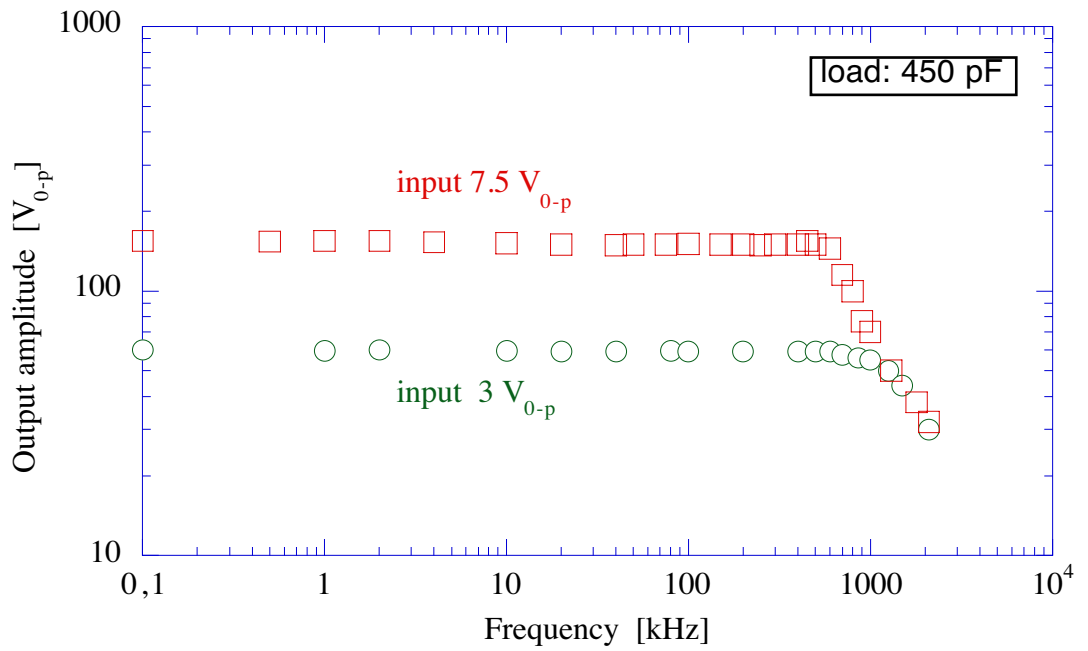

SUMMARY OF TECHNICAL DATA

Bandwidth:		DC to 1 MHz at 100 V _{pp} and 350 pF load
Amplification:		20 times, fixed
Load:	type	resistive capacitive
	SOA	max 450 pF incl. connection cables
Impedance:	input	100 kΩ 30 pF
	output	<0.1 Ω in the linear mode
Voltage:	input	nominal ±10 V
Current:	output	170 mA, each channel
Slew Rate:	output	300 V/μs at 350 pF load
Input protection fuse:		15 mA (Littelfuse, part number 273.010) two spare fuses provided inside the instrument, additional fuses available from FLC Electronics Inc.
Operating Ambient Temperature:		0°C to 30°C
Storage Temperature:		0°C to 60°C
Relative Humidity:		up to 90% (operation) 30% to 50% (storage)
Power Requirements:		100/110 V or 220/230 V, 50/60 Hz
Fuse:		100/110 V: 3.15 A (slow), 220/230 V: 2 A (slow)
Dimensions (H/W/L):		112 x 255 x 316 (mm)
Weight:		4 kg
Country of Origin:		Sweden

Note: Specifications apply to instruments operating at 23°C±5°C ambient temperature after 2 min warm-up time. Due to ongoing product development, specifications are subject to change without notice.

WARNING It is not allowed to connect the 100...230V AC line power input of the amplifier to DC-AC converters or solid state AC generators with non-sinusoidal output.

WARRANTY

FLC Electronics warrants that this product will be free from defects in materials and workmanship for a period of one year from the date of the shipment.

If any such product proves defective during this warranty period, FLC Electronics, at its option, either will repair the defective product without charge for parts and labour, or will provide a replacement for the defective product. In order to obtain service under this warranty, Customer must notify FLC Electronics of the defect before the expiration of the warranty period and make suitable arrangements for the performance of the service. Customer shall be responsible for packing and shipping the defective product to the service center designed by FLC Electronics, with shipping charges prepaid. FLC Electronics shall pay for the return of the product to the Customer if the shipment is to a location within the country in which the FLC Electronics service center is located. Customer shall be responsible for paying all shipping charges, duties, taxes, and any other charges for products returned to any other locations.

This warranty shall not apply to any defect, failure or damage caused by improper use or inadequate maintenance and care. FLC Electronics shall not be obligated to furnish service under this warranty

- to repair damage resulting from attempts by personnel other than FLC Electronics representatives to install, repair or service the product;
- to repair damage resulting from improper use or connection to incompatible equipment;
- to service a product that has been modified or integrated with other products when the effect of such modification or integration increases the time or difficulty of servicing the product.

This warranty is given by the FLC Electronics with respect to this product in lieu of any other warranties, expressed or implied. FLC Electronics and its vendors disclaim any implied warranties of merchantability or fitness for a particular purpose. FLC Electronics' responsibility to repair or replace defective products is sole and exclusive remedy provided to the customer for breach of this warranty. FLC Electronics and its vendors will not be liable for any indirect, special, advance notice of the possibility of such damages.

The instrument may generate hazardous voltage levels! It should be operated by qualified personnel only. The instrument is to be used in normal room temperature and humidity.

The manufacturer cannot be held responsible for damage to any device connected to the instrument. It is recommended that samples or equipment sensitive to voltage spikes are disconnected from the high-voltage outputs when turning the power to the instrument ON or OFF.

I M P O R T A N T



The instrument cannot be powered from a DC-AC converter nor from a solid-state AC generator with non-sinusoidal output.



Loads sensitive to voltage transients should be disconnected from the amplifier during power-up and power-down.



Never connect the output to the input of the amplifier!



Inside the amplifier case exist dangerous voltage levels.



The amplifier may be overheated if the output is short-circuited for a long time.



The maximum allowable capacitive load depend on the internal setting of the slew rate. Overloading the output is likely to cause overshoot. Slow down the amplifier to accommodate a larger load.



It is recommended to monitor the output signal of the amplifier on the oscilloscope.